

CATALOGUE of the Exhibition Equipment

1. Equipment for exposition

[Show cases](#)

[Podiums](#)

[Counters](#)

[Long-span racks](#)

[Shelves](#)

[Video desk](#)

[Archive locker](#)

2. Equipment for stand construction

[Doors](#)

[Panels](#)

[Carpet](#)

3. Furniture and office equipment

[Tables](#)

[Chairs](#)

[Coat racks](#)

[Kitchen equipment](#)

[Liquid-operated cart](#)

4. Electric Equipment

[Spot-lights](#)

[Projector](#)

[Electricity distributing board](#)

[Extension cord](#)

[Telephone set](#)

Showcases

High showcase with shelves



Dimensions (H*W*D, mm):
2500*1000*500

Low showcase



Dimensions (H*W*D, mm):
1100*1000*500

Description:

Variants available:

1. Lockable top-side;
2. Lockable underside;
3. With lights
4. With additional shelves

It is recommended that heavy exhibit items be placed closer to the edges of the shelves. Shelves are made of 5mm glass.

Description:

Variants available:

5. Lockable top-side;
6. Lockable underside;
7. With lights

Podiums

Narrow podium



Description:

This podium is used for displaying different exhibit items including heavy and massive ones, and as a TV-desk. The upper side is made of 10mm chipboard. The upper side of the podium can be hardened at a client's request.

Dimensions (H*W*D, mm):
800*1000*500

Wide podium



Description:

Wide podium is used for demonstrating different exhibits, including heavy and massive ones, and as a base for a flat TV panel. The upper part is made of 10mm chipboard and can be hardened at a client's request.

Dimensions (H*W*D, mm):
800*1000*1000

Counters

Square information counter



Description:

Designed to display exhibits, house information handouts and advertising catalogues and ensure comfortable communication with exhibition participants. For even greater comfort a bar stool can be set at the counter. The desk is equipped with an inside shelf.

Dimensions (H*W*D, mm):

90° information counter



Description:

A 90° corner desk is very comfortable for presentations and can be used with all kinds stands. Is usually put in the corner. A 1.5m frieze can be set above the counter. The desk is equipped with an inside shelf. Booking 2 desks you can achieve the following interesting solution:



Dimensions (H*W*D, mm):

Narrow book counter



Description:

Required for placing information leaflets and handouts.

Dimensions (H*W*D, mm):

Wide book counter



Description:

Required for placing information leaflets and handouts at large stands.

Dimensions (H*W*D, mm):

Long-span rack



Description:

Useful for housing various exhibits including heavyweight and massive.

Often used for storage as a part of back office furniture. Easy to build-in.

Optional elements:

1. Rack shelf.

Dimensions (H*W*D, mm): 2500*1000*500

Shelves

Sloping shelf



Description:

Suitable for placing magazines and other reading matter. Compound – iron.

Dimensions (H*W*D, mm):

Straight shelf



Description:

Designed to demonstrate exhibits, reading and informational matter. Shelves are set horizontally at a 90° angle. Compound – chipboard.

Dimensions (H*W*D, mm):

Video desk

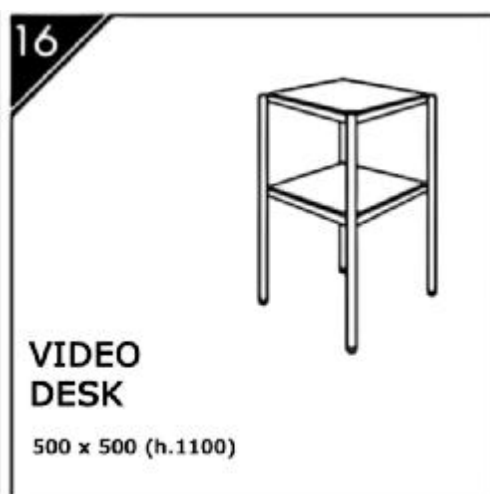

Description:

Designed to hold TV-equipment and related hardware. Lower part can be closed with panels. A 0.8m height version is also available.

Dimensions (H*W*D, mm):
1100*500*500

Archive locker



Description:

Suitable for storing valuable exhibits. The locker is equipped with an inside shelf and a lock. The key is handed to participant till the end of exhibition.

Dimensions (H*W*D, mm):
800*1000*500

Doors

Wing door



Description:

Direction of opening should be set in advance. The key is handed to participants till the end of exhibition. Doors are not covered with Oracal adhesive films.

Dimensions (H*W, mm): 2500*1000

Sliding door



Description:

Can be locked, the key is handed to participant till the end of exhibition.

Dimensions (H*W, mm): 2500*1000

Curtain

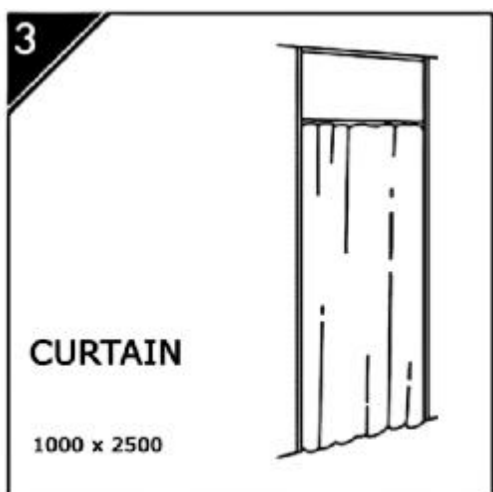

Description:

Color – white.
Opens to both sides.

Dimensions (H*W, mm): 2500*1000

Panels

Wall panel

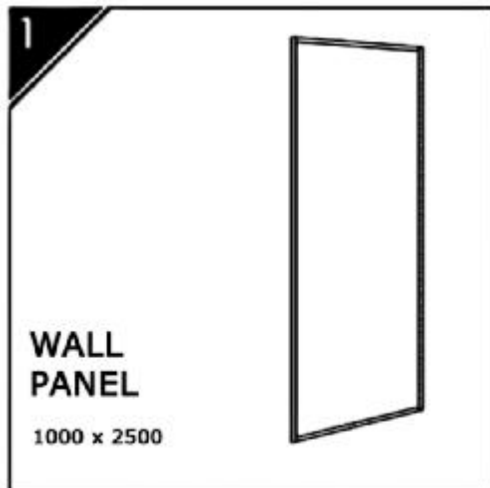

Dimensions (H*W, mm): 2500*1000
2500*500

Description:

Used to make stand walls, allowing to change stand configuration – create dividers, back offices.

Types of panels available:

1. 1x2.5 m
2. 0,5 x 2,5 m

Frieze panel

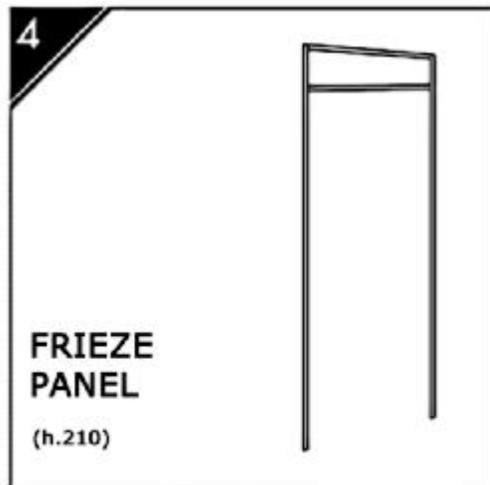

Dimensions (H*W*D, mm):

Description:

Frieze panel made of plastic, marked with a stand name. Maximum length for one panel – 3 meters, minimum – 0.5 meter. Long titles can be placed on two separate panels, divided by a counter.

Barrier



Dimensions (H*W, mm): 800-
1100*1000

Description:

Used to restrict access or direct the visitors flow in a certain direction.

Ceiling panel

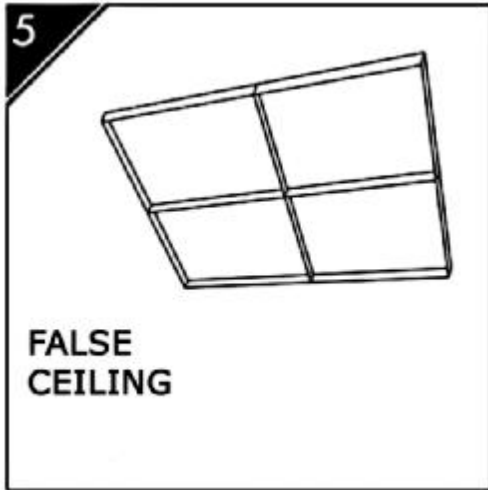

Dimensions: 1000*1000 mm

Description:

Used to create a false ceiling.

Ceiling lathing



Description:
Often used in negotiation rooms.

Dimensions: 1000*1000 mm

Carpet

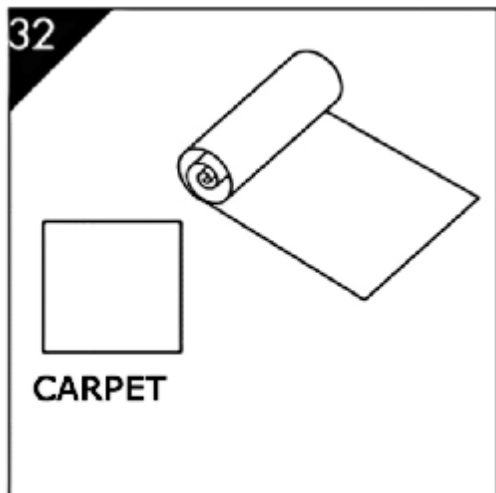

Description:
Default color is gray.
Different color carpet should be ordered at least 2 months prior to exhibition.

Dimensions (H*W*D, mm):

Tables

Negotiations table



Description:

Is usually booked for negotiation rooms.

Dimensions (H*W*D, mm):

750*1300*780

Metal table



Description:

All stands are equipped with white tables on default.

Dimensions (H*W*D, mm):

Plastic table



Description:

Usually used in back offices.

Dimensions (H*W*D, mm):

Wooden table



Description:

A tale with a wooden top. Booked separately.

Dimensions (H*W*D, mm):

Chairs
Office chair



Description:
Included in default and optional stand kitting.

Dimensions (H*W*D, mm):

Plastic chair



Description:
A lightweight chair often used in back offices.

Dimensions (H*W*D, mm):

Bar stool



Description:
Used separately or together with information counters of different kind.

Dimensions (H*W*D, mm):

Coat rack

Wall-mounted coat rack



Description:

Fixed to a wall panel. Fixation points must be negotiated.

Dimensions (H*W*D, mm):

Standing coat rack



Description:

Required to create a mobile wardrobe.

Dimensions (H*W*D, mm):

Wall sheet hook

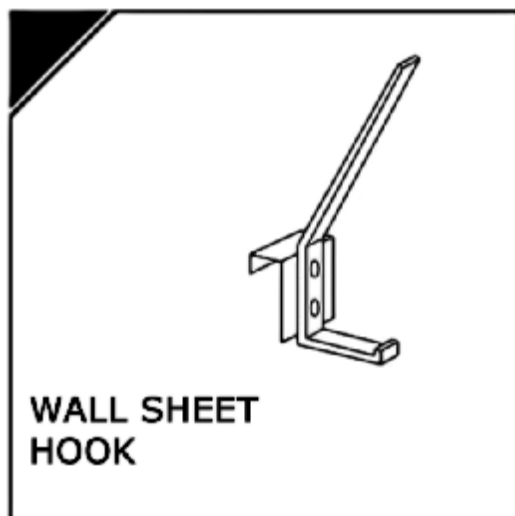

Description:

Designed to hold posters, exhibits and other information matter.

Dimensions (H*W*D, mm):

Kitchen equipment

Wastebasket



Description:

Used to hold liter. Large stands require several wastebaskets.

Dimensions (H*W*D, mm):

Kitchen sink with water supply



Description:

Available with:

1. Cold water supply;
2. Hot water supply.

Dimensions (H*W*D, mm):

850*1000*600

Refrigerator



Dimensions (H*W*D, mm): 1200*580*600

Kettle

Description:

Used for storing perishable goods.

Description:

Electric kettle.

Liquid-operated cart



Description:

Carrying capacity: 2.5 tons.
We recommend using a tray for exhibit transportation.

Dimensions (H*W*D, mm):

Spot-light

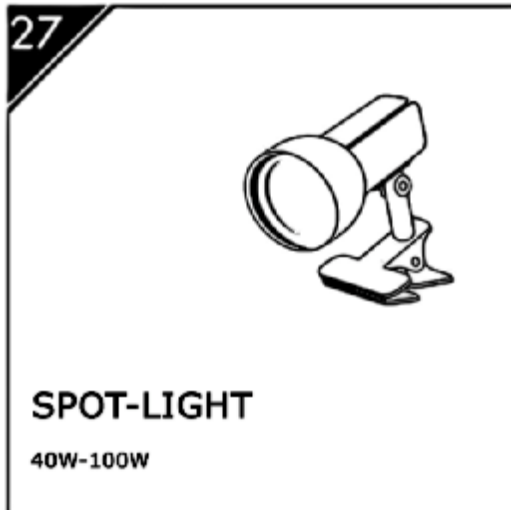

Description:

Power: 40-100 W
Used for spot-lighting the exhibits, room lighting; showcase, counters and other equipment illumination.

Dimensions (H*W*D, mm):

Projector

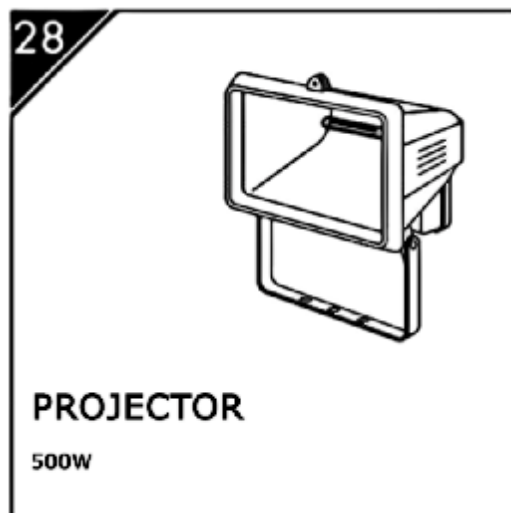

description:

Power: 500-1000 W
Creates a powerful light flux. Used to illuminate exhibits, cars, employed for exclusive stand lighting.

Dimensions (H*W*D, mm):

Electric switchboard

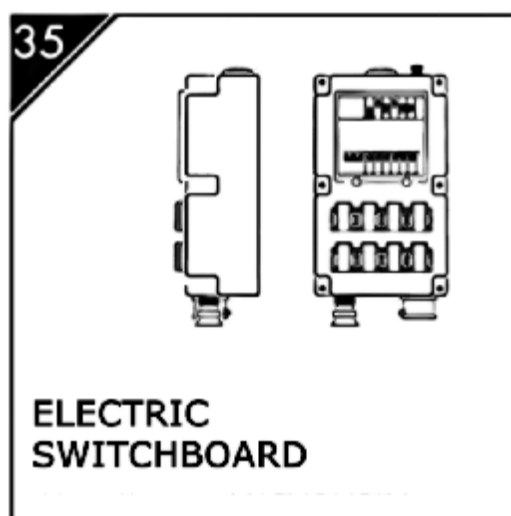

Description:

Used to provide exhibits with electric power supply.

Dimensions (H*W*D, mm):

Extension cord

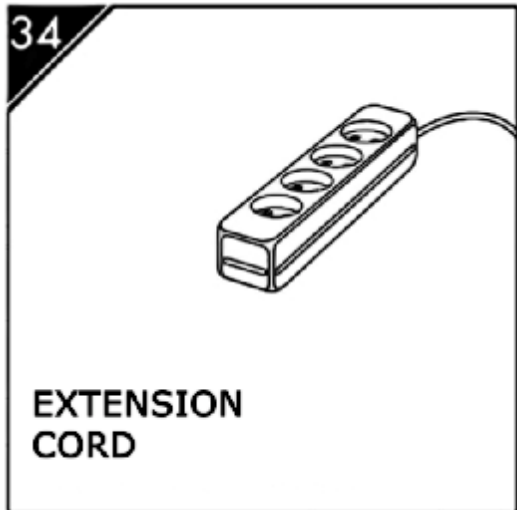

Description:

Length – 3-5 meters
Number of sockets – 2-4.

Dimensions (H*W*D, mm):

Telephone set



Description:

Provides telephone communication.